

Political Sign Fact Sheet



This document is intended for guidance only and does not relieve property owners or candidates from specific provisions of the Sign Code. Copies of the Sign Code are available for inspection at the City Offices or are available online at www.bellavistacityar.com.

General Requirements

- Political signs *do not* require a permit but must have the property owner's permission.
- Political signs must contain the name, address, and telephone number of the person responsible for the sign.
- Political signs must be maintained in good condition.
- Political signs must be made from a durable, weather resistant material.
- Political signs can not be located within the public right-of-way. (See Administrative Policies, below.)
- Political signs can not be attached to utility poles, street signs, boxes, rocks, trees, etc. in the right-of-way.
- Political signs can not obstruct driver's vision clearance at intersections and so can not be located within the "sight triangle". This is a triangular area formed by a diagonal line connecting two points measured 35 feet away from the pavement edge intersection. (See diagram, below.)

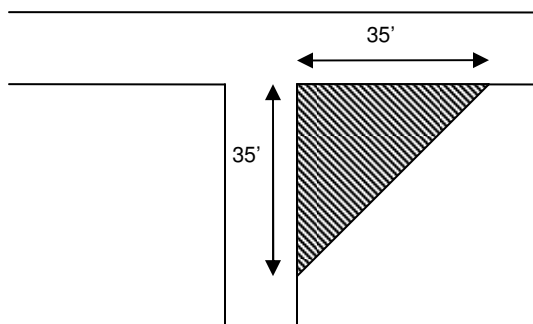

Sight Triangle

Residential Districts

- Maximum area: 5 square feet
- Maximum Number: 1 sign per 20 linear feet of street frontage the property borders

Non-Residential Districts

- Maximum area: 18 square feet
- Maximum Number: 1 sign per 20 linear feet of street frontage the property borders

For Questions Contact:

City of Bella Vista
Planning and Code Enforcement Department
416 Town Center Northeast
Bella Vista, Arkansas 72714
(479) 876-1255

Administrative Policies

- Political signs placed illegally within the right-of-way will be removed immediately.
- Rights-of-way in Bella Vista are difficult to determine due to a lack of visible monumentation. The Administration utilizes the following visual markers for enforcement of the right-of-way provisions of the ordinance:
 - Where electric poles are present, signs should be placed beyond the pole away from the road surface.
 - Where no poles are present, signs should be placed at the top of slope of drainage ditches away from the road surface.
 - Where no poles or ditches are present, signs should be placed no closer than 15' away from the road surface.
- Political signs will be held for one week for owner retrieval. If not retrieved, signs will be thrown away.
- Violations of the sign ordinance can result in fines of \$250 - \$1000 per week with each week a separate violation.