

# Yard Sale Sign Fact Sheet



*This document is intended for guidance only and does not relieve property owners or those conducting yard sales from specific provisions of the Sign Code. Copies of the Sign Code are available for inspection at the City Offices or are available online at [www.bellavistacityar.com](http://www.bellavistacityar.com).*

## General Requirements

- “Yard sale signs” include, but are not limited to, signs that advertise yard, garage, moving, estate, auction, or rummage sales.
- Yard sale signs *do not* require a permit but must have the property owner’s permission.
- Yard sale signs must contain the name, address, and telephone number of the person responsible for the sign as well as the address, date(s), and time of the sale.
- Yard sale signs must be maintained in good condition.
- Yard sale signs must be made from a durable, weather resistant material.
- Yard sale signs must be securely attached to the ground with a pole or stake.
- Yard sale sign should be placed at least 6 feet away from the edge of the road, and placed no further than 5 miles away from the property.
- Yard sale signs can not be attached to utility poles, street signs, boxes, rocks, trees, etc. in the right-of-way.
- Yard sale signs can not obstruct driver’s vision clearance at intersections and so can not be located within the “sight triangle”. This is a triangular area formed by a diagonal line connecting two points measured 35 feet away from the pavement edge intersection. See diagram below.

- **Time:** Signs may not be posted sooner than 3 days prior to the sale and must be removed the final day of the sale.
- **Maximum Number:** 1 sign at the sale site, and 5 off-site directional signs.
- **Maximum Area:** 5 square feet

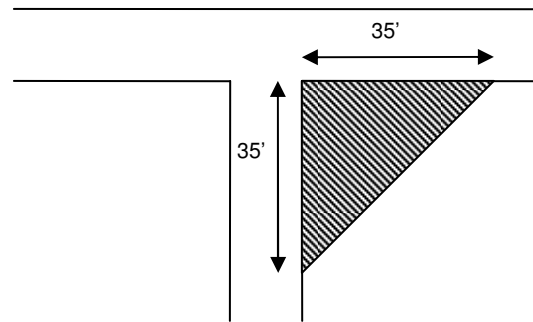

**Sight Triangle**

## Administrative Policies

- Yard sale signs placed illegally within the right-of-way will be removed immediately.
- Yard sale signs will be held for one week for owner retrieval. If not retrieved, signs will be thrown away.
- Violations of the sign ordinance can result in fines of \$250 - \$1000 per week with each week a separate violation.

## **For Questions Contact:**

City of Bella Vista  
Planning and Code Enforcement Department  
416 Town Center Northeast  
Bella Vista, Arkansas 72714  
(479) 876-1255